

# EFFECETIVE TRANSFORMER CONDITION ASSESSMENT

Luwendran Moodley, Doble Engineering Africa

## **Abstract**

*This paper details a novel approach to transformer condition assessment. This method has proven itself for many years in very large utilities throughout the world. The implementation of this two phase approach is discussed in great detail.*

## **1. Introduction**

The catastrophic failure and poor performance of transformers is becoming a constant grim reality in the life of Maintenance Engineers and Asset Managers in South Africa. Most of which are left powerless in this struggle due to financial constraints imposed upon them when it comes to the huge capital investment that is required to replace a power transformer and the ever dwindling shortage of highly technical staff. Further to this is the ever increasing delivery time for power transformers. So the message is clear *"Make do with what you got and implement a long term replacement exercise"*. The question still in the minds of Maintenance Engineers and Asset Managers is *"How do I do this if I do not know the condition of my transformer?"* The answer is effective condition assessment

## **2. Transformer Condition Assessment**

What we know about transformers is that their life expectancy can vary from a few cycles (ms) to more than fifty years. This fact is interesting but not very useful to an engineer responsible for a given network.

What we need to know is the life expectancy of a particular transformer in a given network. This fact is interesting and very useful. This is the essences of condition assessment.

Effective condition assessment is not just testing a transformer and reproducing the test results nor is it diagnosing the cause of a failure after the transformer has failed. Cigre Working Group on Life Management Techniques for Power Transformers has defined condition assessment as *"A comprehensive assessment of the condition of a transformer taking into account all relevant information eg. Design information, service history, operational problems, and results of condition monitoring and other chemical and electrical tests"*. This is an excellent definition that

encompasses all aspects of the transformer's life. This model has been successfully implemented in a number of utilities world wide. However, can effective condition assessment be implemented in utilities with little to no information?

By using Doble's two phase process for condition assessment utilities with little documented information can enjoy the benefits of a comprehensive condition assessment on all types of transformers on the network.

## **3. Doble's Condition Assessment**

Doble's condition assessment program is a two phase process. Both steps include proprietary risk scoring system and combine analysis of individual units and FMMAA analysis (family /make/ model/ application/ age) of similar designs with similar operating conditions and age. FMMAA analysis is based on existing Doble's equipment performance database with test results and equipment failure and trouble data collected from Doble's customers over more than 40 years.

### **3.1 Phase One**

This phase is applied to all units in the network and does not require the units to be removed from service. Phase one of assessment is a "scanning" approach and is more appropriate as a low cost assessment and step to provide "initial" risk assessment and ranking of transformers in a network. This should identify the group of units that are in a sound condition and at a low risk due to their technical condition. The remainder, those identified as higher risk can then be selected for more detailed "Phase Two" investigation, as identified in the following section, 3.2.

The first step is essentially a review of available information. These include as much as possible of the following:

#### **3.1.1 Step 1: Basic nameplate information from transformer and tapchanger.**

All information related to the transformer's manufacturer, vintage, serial number design, ratings, BIL, fault level, impedance, cooling system etc must be captured. From this information design related issues with transformers, service advisories from manufacturers, reports of failure on similar designs, pattern of failure on similar designs can

be identified. The above can be obtained from Doble's database with test results (25 million results) and equipment failure data collected for over 40 years.

**3.1.2 Step 2: External visual inspection.**

A visual inspection is conducted on the following:

- Plinth – check for cracks or deterioration, anchor bolts missing or rusty, evidence of oil leaks, ground leads or connectors oxidized/tight etc.
- Tank - Paint peeling and rust, signs of internal deformation or overheating, oil leaks, loose or missing nuts, bolts, or washers, record liquid level in main tank or any conservator tank, inspect liquid level gauges and wiring, inspect pressure relay and pressure relief device and wiring etc
- Cooling system - Paint peeling and rust, oil leaks, inspects pumps and wiring, inspect fans and wiring, inspect radiators for cleanliness, etc
- Temperature reading - Record temperatures, record position of maximum pointers, inspect temperature sensors and wiring, etc
- Marshalling kiosk - Inspect external for paint peeling and rust, inspect interior for water ingress and rust, heater operating, inspect breakers, contactors, terminals, wiring, etc
- Tapchanger - Paint peeling and rust, signs of internal deformation or overheating, oil leaks, loose or missing nuts, bolts, or washers, record liquid level inspect pressure relay and pressure relief device and wiring, record number of operations, inspect tap changer mechanism, etc
- Bushing - Chipped or broken sheds, oil leaks, oil levels, Inspect connections, etc
- Surge Arrester - Chipped or broken sheds, inspect connections, etc

**3.1.3 Step 3: Review of all available documentation**

- Factory test report - Used to compare with current test results and operating ability
- Purchasing specification - Used to compare to current manufacturing standards
- Tests results (electrical and oil) - Current data can be compared to Doble database for industry norms

- Failure reports - Indicates the rate of aging, availability and performance
- Maintenance practices - What are you doing?
- Major modifications or rebuild - Indicates the rate of aging generally expected
- Substation fault level - Changes in fault rating
- Loading - Used to calculate loss of life

**3.1.4 Step 4: Additional non invasive tests**

*(i) Oil tests (main tank)*

A sample would be taken and analyzed with the standard methods. The table below gives a few standard oil tests.

Dissolved Gas (DGA)	Detection of incepted faults – IEEE, IEC etc
Furfuraldehyde (FFA)	Paper insulation degradation – Chendong relation to DP
Moisture in oil	Insulation dryness
Breakdown Voltage	Dielectric integrity
Acidity	Ageing and sludge
Interfacial Tension	Ageing, sludge and contamination

*(ii) Doble DGA Scoring System*

Doble has developed an algorithm to mimic the key gas response and gives a single number to track the change in pattern. This method uses the key gas method to present DGA used by IEEE method. The relative proportions of the si combustible gases CO, H2, CH4, C2H4, C2H6 and C2H2 are displayed as a bar chart to illustrate the gas signature. The novel aspect of the approach proposed here is that this method is used to investigate and illustrate the clear difference that exists between 'normal' and 'abnormal' results. By contrast, in the IEEE Guide four examples of faults are given, but there is no guidance on what a normal result would look like. The DGA score reflects the seriousness of the signature. DGA results for normal transformers would be expected to return a score of no more than about 30, whereas a core circulating current would rate about 60 and more serious problems would score around 100.

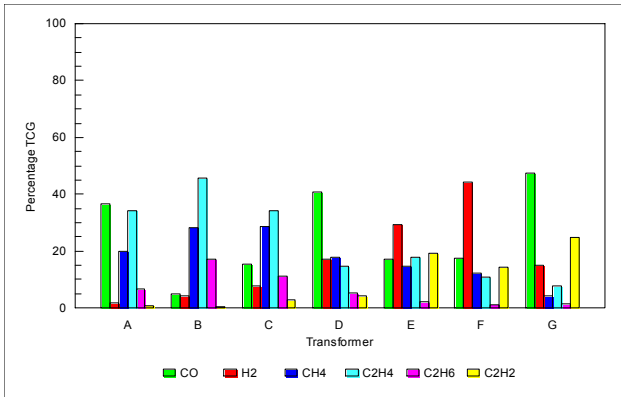

Figure 1: DGA signatures for faulty transformers

- A – Core bolt fault
- B – Core and frame to earth circulating currents
- C – Winding inter-stand fault
- D – Winding shorted turns
- E – Winding phase to earth fault
- F – Winding tracking fault
- G – Winding clamping bolt sparking fault

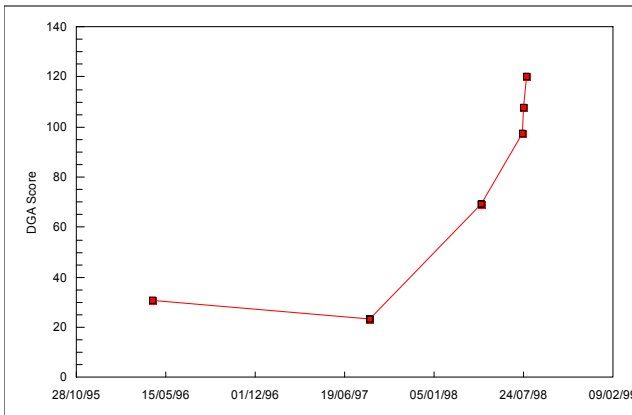
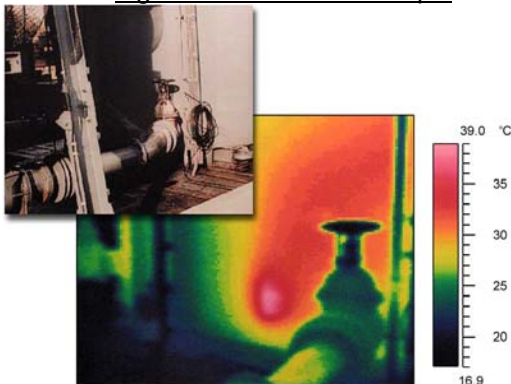

Figure 2: DGA score for core earth fault

(iii) *Infra Red Scan*

Infra-red will indicate external joint issues, bushing tap problems, oil levels in bushings and radiators, blockages in radiators, fan function- it can also indicate tank heating from stray flux, or frame tank circulating current. The figure below illustrates an internal tank hot spot.

Figure 3: IR scan of a hot spot



(iv) *UHF – RIF Scan*

UHF interference surveys have been undertaken for the last 20 years in UK. Corona will produce interference up to a few 10s of MHz, and surface discharge in contamination on bushings has a spectrum extending to 200MHz. However, when internal partial discharge occurs the spectrum extends to 1GHz. Scanning 300-600MHz has proven effective in identifying a range of substation faults, including discharge at faulty bushing taps and within the main tank itself. The figure below illustrates a UHF scan with discharge activity on one tap position only.

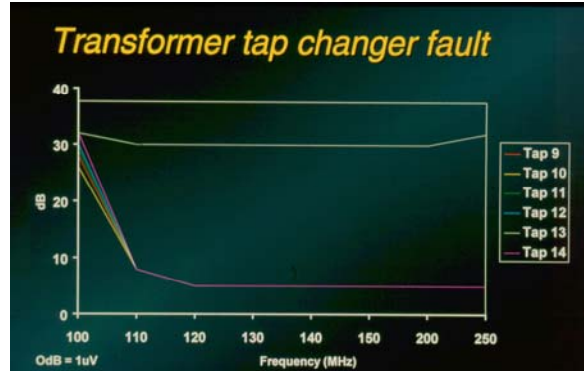

Figure 4: UHR scan

3.1.5 Step 5: **Consultation with staff**

Consultation with all staff involved in the life management of transformers forms an integral part of this process in that this is a great source of information that has not been documented.

3.1.6 **Assessment of Technical Condition**

Once all the information has been gathered and the additional non invasive tests performed the transformers can then be scored based on its condition. The Doble scoring system is given below.

Condition	Definition	Score
New	No damage	1
Normal ageing	Reasonable for age	3
Aged	Some ageing – in need of some monitoring	10
Suspect	Identified ageing, significant risk for failure	30
Unacceptable	Unacceptable ageing	100

Transformers condition is further divided in design, dielectric, thermal and mechanical and scored to a Doble scoring system. A typical assessment of the technical condition is given below.

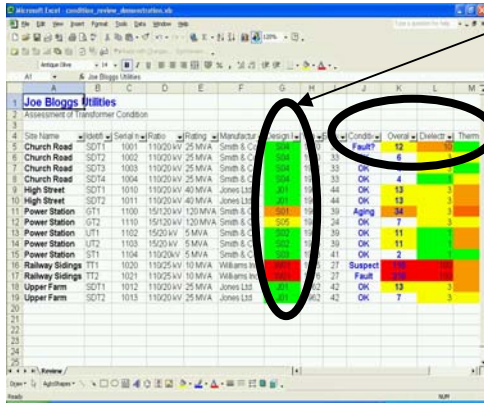

Designs are rated after review of Doble database.

Transformers condition is divided in dielectric, thermal and scored

- Ratio test

Note: Explanation on the above electrical tests is given in the Appendix A.

### 3.2.1 Rescoring the Technical Condition

Once all the off line tests are performed the technical condition of each transformer can be rescored with greater detail. This is shown below.

Unit Level	Condition	Weighting	Risk
Thermal	10	0.8	8
Dielectric	30	0.8	24
Mechanical	3	0.6	1.8
Core	10	0.4	4
Oil	3	0.8	2.4
Tank	3	0.2	2
Bushings	3	0.8	2.4
Tapchanger	3	0.6	1.8

All units have been assessed in terms of design groups with problems, overall condition, thermal and dielectric condition. Also included in the assessment is a score for the design group, tap changer, bushings and surge arresters. Each aspect has its own score - a number between 1 and 100. Even with summation any aspect with a 100 score will be carried through and easily recognized. The results are assessed using this sum of the numerical scoring system and it is this sum that determines the position in the "league table" and summarized using a red- green colour traffic light code. It should be emphasized that the score is not permanent it's a "live" document, reviewed each month as new evidence is presented.

### 3.1.7 Outcomes of Phase One

Once this process is completed the following is made evident:

- Establishment of an asset register
- Design weakness
- High risk transformers in terms of the dielectric and thermal condition
- High risk transformers in terms of the environment, staff and third parties

All the transformers that fall in the above category would then be considered for phase two of the condition assessment process.

### 3.2 Phase Two

This phase is applied only to units that have been identified as high risk from Phase One.

The Phase Two process is shown in Figure 2 (see end of paper.) This phase is a comprehensive analysis of the transformer and requires off line testing. The standard off line tests are as follows:

- Tan  $\delta$  and Capacitance - windings and bushings
- Sweep Frequency Response Analysis
- Leakage reactance
- Insulation Resistance
- Winding resistance
- Exciting current

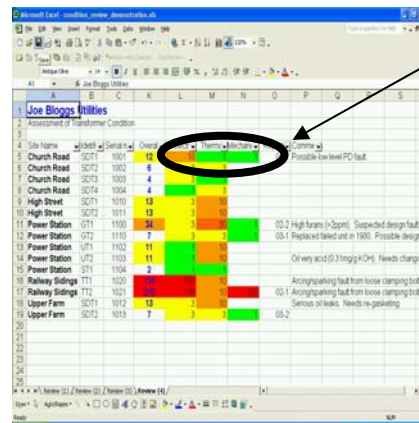

This example is based on a population where oil test data is supplemented by a reasonable amount of electrical test data.

The rescoring now includes the mechanical condition of the transformer. With the final scoring for the condition of the transformer now in place a weighting for each unit level can be assigned. From this a risk of each unit level can be determined. A total risk of each transformer can then be calculated.

### 3.2.2 Outcomes of Phase Two

Once the rescoring has been completed the following is made evident:

- High risk transformers in terms of the dielectric, thermal and mechanical condition.
- More accurate overall condition as a result of the off line tests
- An action plan in terms of units that require replacement, repair and monitor
- The transformers risk

The results of phase two are merely added to the existing assessment. A typical layout is shown below.

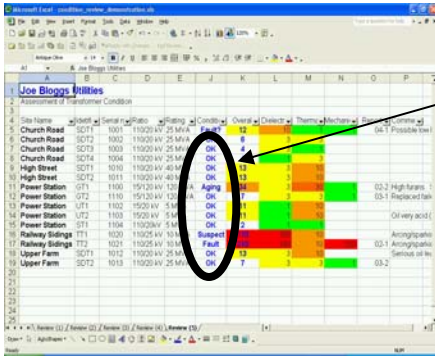

Most of the population are OK!

One has a fault, one is aged and another might have a fault.

[2] J.A Lapworth, "A scoring system for integrating dissolved gas analysis results into a life management process for power transformers" Proceedings of the 2002 International Conference of Doble Clients, Boston, MA

[3] Wilson A, JA Lapworth, "Asset Health Review to Manage Remaining Life" IEEE PES Power Africa, Johannesburg, South Africa, 2007

[4] CIGRE Working Group 12.18, "Life Management of Power Transformers"

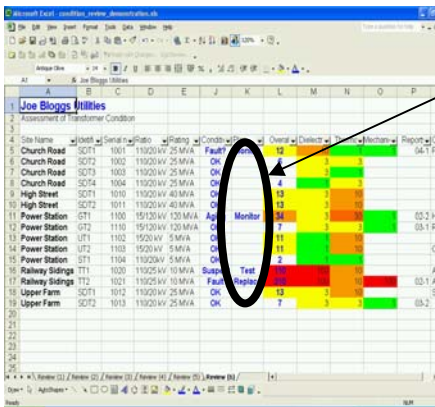

No need for action plans for most of the population.

The faulty transformer needs to be replaced. The sister transformer needs to be tested.

#### 4. Conclusion

Transformer condition assessment program can be effectively introduced by using this two phase approach. This method of condition assessment can be implemented irrespective of the amount of information. It allows utilities to finally have answers to the following situations:

- When to have maintenance outages
- How to respond to a protection trip
- To know capability to increase transformer rating
- To know when to replace (5, 10, 15 years) transformers

An added advantage is that this method forces the utilities to make the bold move to condition based maintenance. A further advantage is the risk assessment and residual life can finally be achieved through sound engineering principles.

#### REFERENCES

[1] Wilson A, "Impact of technical condition in utilization of power transformers" Proceedings of the 2002 International Conference of Doble Clients, Boston, MA

## APPENDIX

### Electrical Testing of Transformers

#### Tan $\delta$ and Capacitance - Windings

Tan  $\delta$  (dissipation factor) is merely the tangent of the loss angle that is created by the capacitive and resistive current that is present in a dielectric medium. Measurements are typically made between the high voltage winding to ground, between the high voltage and low voltage winding and between the low voltage winding to ground. This measurement method allows assessment of individual winding hence focusing on the area of deterioration. As Tan  $\delta$  is dependent on temperature the measure values are normalized to 20 °C by applying a correct factor.

Tan  $\delta$  is an evaluation of the quality of the insulation and is size independent. Tan  $\delta$  has proven to be effective in detection of the following problems in transformers of all sizes:

- Moisture;
- Carbonisation of insulation;
- Contamination of oil by dissolved materials or conducting particles; and
- Improperly grounded core.

Winding capacitance on the other hand evaluates physical makeup of insulation system which is size dependent. Capacitance measurements have proven over the year to be very effective if reference results are available. Changes in the region of 10% would normally indicate extreme winding movement. However, this method of detecting winding movement is not as effective as Sweep Frequency Response Analysis.

#### Tan $\delta$ and Capacitance – Bushings

If bushings are equipped with a test tap two measurements can be performed which are a  $C_1$  and a  $C_2$ . The  $C_1$  test measures the condition of the main bushing insulation to the test tap. The  $C_2$  test measures the condition of the test tap insulation to ground and core Insulation between tapped layer and bushing ground sleeve.

The  $C_1$  and  $C_2$  tests are effective in identifying the following defects:

- Moisture ingress;
- Carbonisation of insulation;
- Short circuited condenser layers;
- Contamination of oil by dissolved materials or conducting particles; and
- Open circuits such as break in the band between the ground and mounting flange.

#### Exciting Currents

The exciting current is, for practical purposes the current that flows when the winding of a transformer is energized under no-load conditions.

The exciting current creates a magnetic flux in the core, and the flux in turn induces a voltage in the energized winding that opposes the applied voltage. Consequently, the exciting current is small, usually only a few percent of the rated load current of the winding. The exciting current of a transformer is made of three components:

(a) A magnetizing part ( $I_m$ ) required to build the magnetic field in the transformer core. It is often referred to as the magnetizing current.

(b) A resistive part ( $I_r$ ) required to supply all the losses in the transformer at no load.

(c) A capacitive part ( $I_c$ ) required to build the electrical field in the insulation of the transformer.

This is a single-phase test that was introduced in North America as a diagnostic tool in 1967 and today is part of standard insulation tests in the field. The single-phase exciting-current test is useful in locating problems such as defects in the magnetic core structure, failures in the turn-to-turn insulation, or problems in the tap-changing device. These conditions result in a change of the effective reluctance of the magnetic circuit, which consequently affects the current required to force a given flux through the core.

The diagnostic analysis of exciting current test results is based largely on pattern recognition.

#### Ratio Test

Doble's method uses a high voltage (10 kV) and involves measuring the capacitance of the capacitor by itself and the apparent capacitance when it is connected across the low voltage winding. The ratio of these to capacitance yields the turns ratio of the transformer. The greatest advantage of this high voltage test method is that high resistance areas can be overcome, where as low voltage test sets might show such an area as an open circuit. Ratio test has been used very successfully over a number of years for the following:

- Confirm ratios are within 0.5% of nameplate data;
- Detect short circuited turn-to-turn;
- Detect open circuit windings; and
- Confirm tap lead connections.

#### Sweep frequency response Analysis (SFRA)

The loss of mechanical integrity in the form of winding deformation and core displacement in power transformers can be attributed to the large electromechanical forces due to fault currents, winding shrinkage causing the release of the clamping pressure and during transformer transportation and relocation. These winding deformation and core displacement if not detected early will typically manifest into a dielectric or thermal fault. This type of fault is irreversible with

the only remedy been rewinding of the phase or a complete replacement of the transformer. It is therefore imperative to check the mechanical integrity of aging transformers periodically and particularly after a short circuit event to provide early warning of impending failure. Hence an early warning detection technique of such a phenomena is essential. Frequency response analysis is recognized, as been the most sensitive diagnostic tool to detect even minor winding movement and core displacement.

The transformer is considered to be a complex network of RLC components. The contributions to this complex mesh of RLC circuit are from the resistance of the copper winding; inductance of winding coils and capacitance from the insulation layers between coils, between winding, between winding and core, between core and tank, between tank and winding, etc. However, a simplified equivalent circuit with lumped RLC components as illustrated in Figure 1 can be used to accurately explain the principle of frequency response.

Any form of physical damage to the transformer results in the changes of this RLC network. These changes are what we are looking for and employ frequency response to highlight these small changes in the RLC network within the transformer. Frequency Response is performed by applying a low voltage signal of varying frequencies to the transformer windings and measuring both the input and output signals. The ratio of these two signals gives the required response. This ratio is called the transfer function of the transformer from which both the magnitude and phase can be obtained. For different frequencies the RLC network offers different impedance paths. Hence, the transfer function at each frequency is a measure of the effective impedance of the RLC network of the transformer. Any geometrical deformation changes the RLC network, which in turn changes the transfer function at different frequencies and hence highlights the area of concern.

Impedance at different frequencies relate to the resistance, capacitance and inductance of a transformer. The resistance is related to the physical construction of the winding (shorted turns, core earth etc.) and results in the vertical shift (dB axis) of the response. The capacitance and inductance are related to the geometry of the winding (deformation) and results in a horizontal shift or frequency shift.

At the lower frequency range the capacitance of the transformer can be disregarded and the

response is purely inductive. At these frequencies the inductance of the magnetic circuit dominates. There is a significant difference in the responses between the outer two phases and the center phase at this frequency range. This is due to the flux paths of the core. The center phase has two flux paths of equal reluctance and the outer phase has two flux paths of different reluctance. As a result the outer phases has two resonance points as compared to the center phase that has just one resonance point. This also accounts for the difference in the starting dB values.

At higher frequency ranges the response look very confusing and complex as a result of the numerous resonance points. At this frequency range the winding inductance dominates with the magnetic circuit effectively screened. Hence, the winding responses are less dependent on the magnetic circuit, which makes the measurement more sensitive to winding deformation. At the highest frequencies the inductance can be disregarded and the response is effectively capacitive.

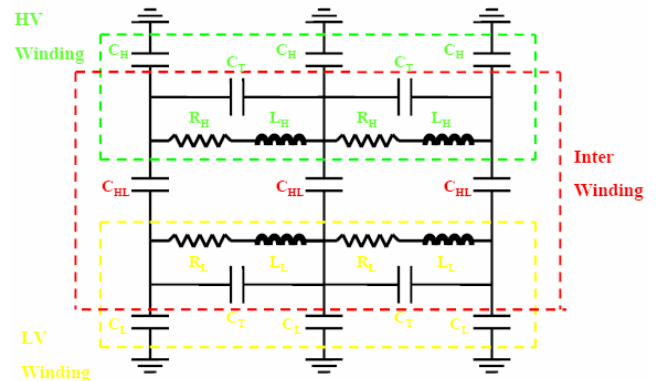

Figure 1: Simplified equivalent circuit with lumped RLC components

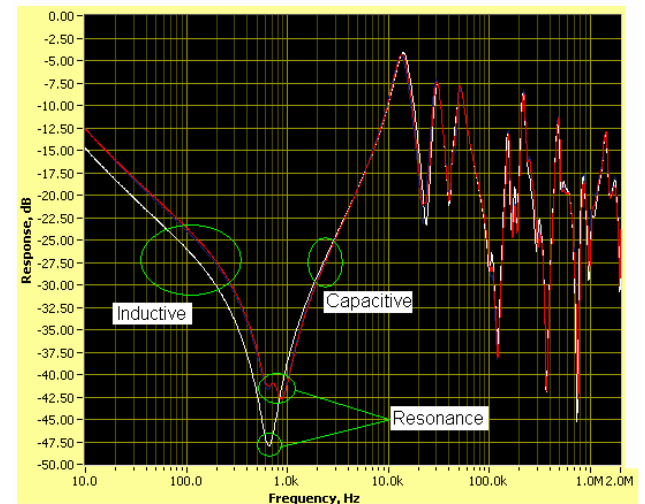

Figure 2: Frequency Response of a sound transformer